

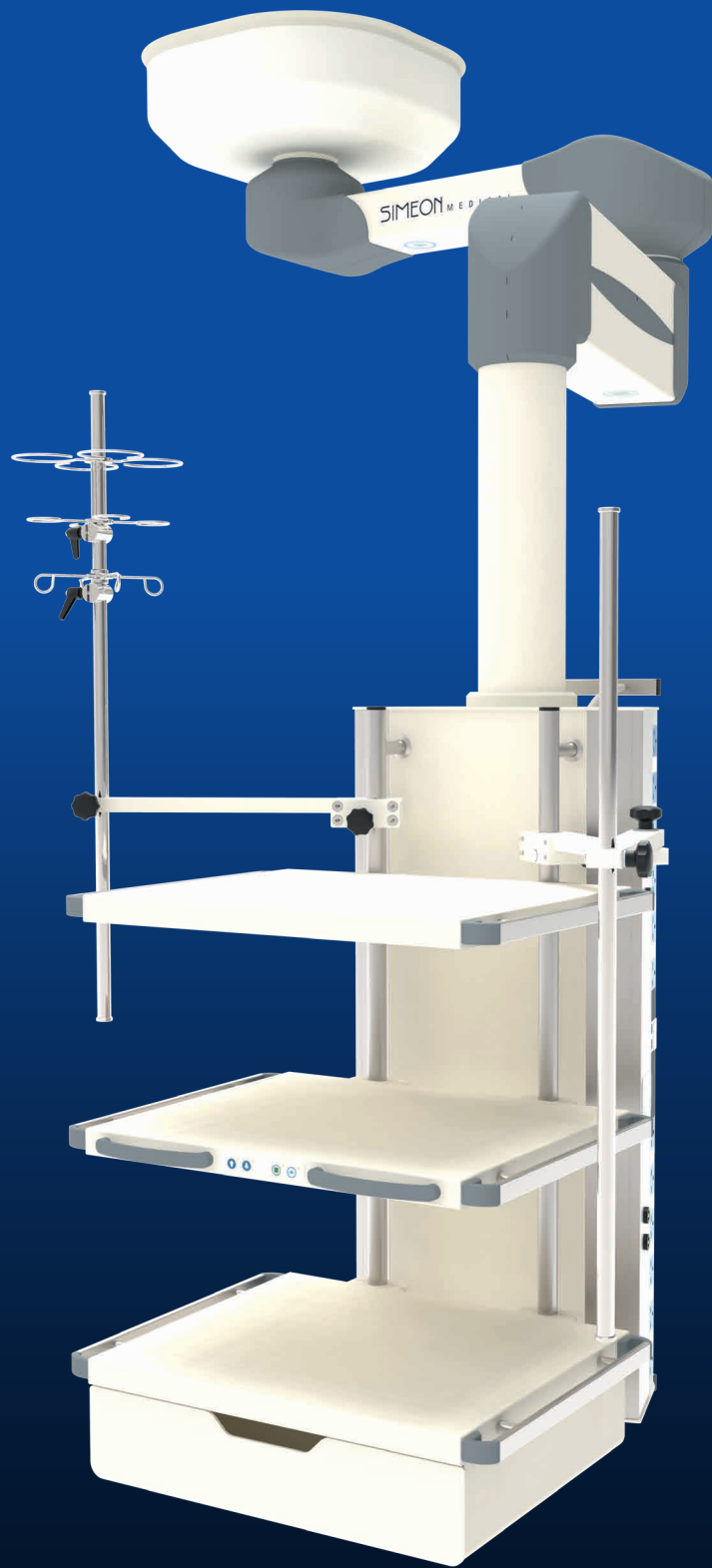

PUSHING TECHNOLOGY TO EXCELLENCE



Sim.CARRY

The ideal supply manager in the OR and in intensive care

ADVANTAGES OF THE

Sim.CARRY CEILING SUPPLY UNITS

Flexibility



Wide variety suitable for all common disciplines and application areas

Variety



Availability of all internationally common standards as well as adapters for all common anesthesia devices

State-of-the-art technologies



State-of-the-art technologies such as eBrake, indirect room lighting, etc.

Hygiene-optimized design



Hygiene-optimized design for easy cleaning



OVERVIEW OF

PRODUCT HIGHLIGHTS

Sim.CARRY ceiling-mounted supply units offer you various product highlights that provide you with the best possible support in your daily work in the operating room or in the intensive care unit. We offer you a selection of different brake systems such as the pneumatic brake and the low-maintenance electromagnetic eBrake.

Furthermore, thanks to the modularity of our products, you have a large number of different extension arm systems to choose from. Discover them for yourself!

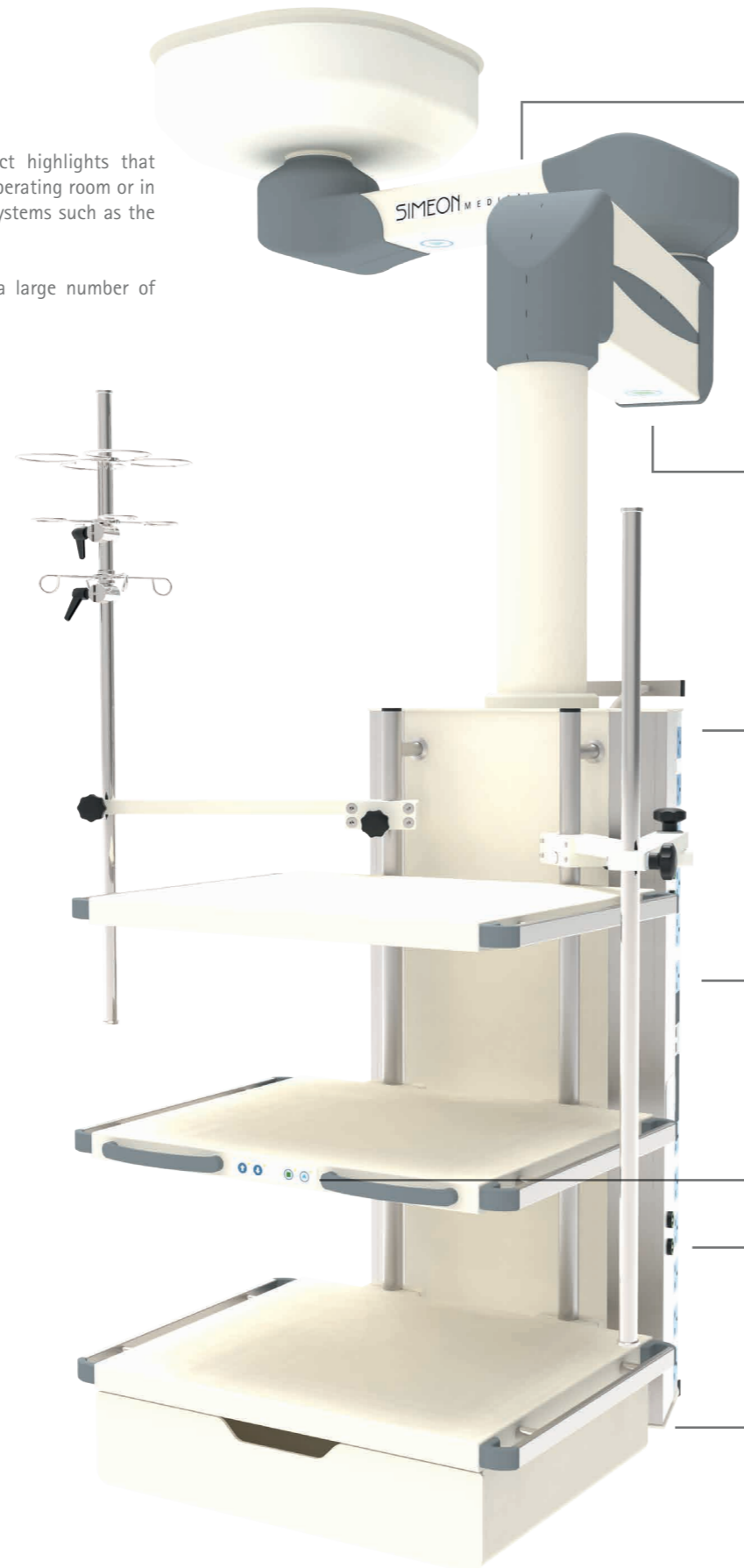

Indirect room lighting

Ambient light for indirect lighting of the intensive care ward, on the upper extension arm towards the ceiling and on the underside of the supply console towards the floor

Electromagnetic eBrake

With visual feedback when the brakes are activated and clear assignment of the brakes by means of redundant symbols on the control panel and extension arm



Symbols on the extension arms enable easy identification of the brakes

Extremely versatile

In addition to adapters for all standard anesthesia devices, we offer all internationally widespread electrical, data & video and gas standards

Easy to use

Intuitive and redundant control panel on console and tray for easy operation and positioning of the ceiling-mounting supply unit, including brake activation and motorized arm operation



Individually adaptable to your needs

Great flexibility thanks to multi-function rack for mounting various accessories such as infusion poles, trays, monitor mount, etc.

Large selection of individually installable consoles in various lengths and application-specific designs



Sim.CARRY - MODULAR AND FLEXIBLE CEILING SUPPLY UNIT

Workplaces in the operating room and intensive care have always placed growing demands on ensuring that equipment and medical gases are available in close proximity to the patient. The use of swiveling ceiling supply units has long proven itself to be a practical solution.

The Sim.CARRY ceiling supply unit can be put to interdisciplinary use in all conventional specialist fields in the operating room and intensive care and offers an ideal adaptation of the equipment to the individual and application-based requirements.



Perfectly managed

- Ideal cable management thanks to numerous media connectors and spacious cable ducting
- Optimum space usage, since all components are height-adjustable on a multi-function rack
- Suspension arm systems with a radius of action of up to 2,000 mm
- Variably combinable and always in the right position: great freedom of movement in the operating room and at the patient's bedside in the intensive care unit



Individual and custom-built solutions

- Modular principle: Various modular supply consoles adapted to your individual needs
- All conventional electrical, data & video and gas standards can be implemented
- Plenty of room to add individual equipment and add-on options machines
- Hassle-free integration of all communications facilities



Safety and hygiene

- No stumbling blocks
- Different suspension arm systems are available, enabling optimal access to the patient and to all required devices
- Constant availability of power and medical gases right where they're needed
- No sharp edges or corners ensure easy cleaning
- Secure cable management
- Buttons for manual brake control (pneumatic or electromagnetic) are mounted on the tray for easy access

Maintenance and service-friendly

- Easy installation and maintenance
- Large conduit for supply lines
- Can be modified and expanded at any time
- Easy servicing without tools



Ergonomics

- Flexible positioning
- For motor arms: 500 mm height adjustability for ideal workplace ergonomics
- Multi-function rack
 - Available in various lengths up to 1,500 mm
 - Suitable for trays, monitor holders and infusion modules
- Trays (optionally available with drawers) can be flexibly attached and continuously adjusted

Secure investment for the future

- Expandable without tools, allowing additional accessories
- Pneumatic and electromagnetic brakes available
- Electromagnetic brake eBrake
 - Impressively maintenance-free
 - No compressed air supply necessary

Sim.CARRY – INDIVIDUALLY ADAPTABLE

Fulfillment of the specific requirements of the individual specialized disciplines and adaptation to national standards are only possible with the help of a customer-specific solution. Optimized individual adaptability lays the foundation for easy product configuration and ideal application orientation.

For instance, all supply consoles of the Sim.CARRY ceiling supply unit are individually adjustable and can be ideally adapted to meet the customer's needs. The basis for this is formed by the various versions of the supply consoles with a wide range of sizes and capacities for equipment.

Thanks to the modular construction of Sim.CARRY supply consoles, SIMEON offers all common electrical, data & video and gas standards. All conventional gas types are available in the international standards DIN, UNI, AFNOR and BS (incl. NIST), etc. With electrical outlets too, SIMEON offers all common standards, like DIN, BS, US, Swiss Mosaic, etc. Furthermore, a large selection of color markings is available for the outlets – from green to orange, red and white to outlets with LED illumination.

Horizontal supply console "A"

- Horizontal supply console for mounting a wide array of installation components and trays
- Enables space-saving placement of e.g. seven gas outlets, twelve electrical and data outlets, as well as trays and much more
- Optimized cable management
- Adaptable to all available Sim.CARRY suspension arm systems
- Allows individual placement of all installation components and trays and accessories
- Tool-free exchange and expansion of installation components in the console
- Wide variety of accessories available for supply consoles, such as the Sim.LED 250 examination light for fastening to standard rails

Equipment example

1x AGSS
1x 7 bar compressed air / surgical air (air motor)
7x gas outlets
6x pressure gauges
12x 230V electrical and data outlets
10x grounding bolts
2x standard rails
Trays
2x multi-function rack

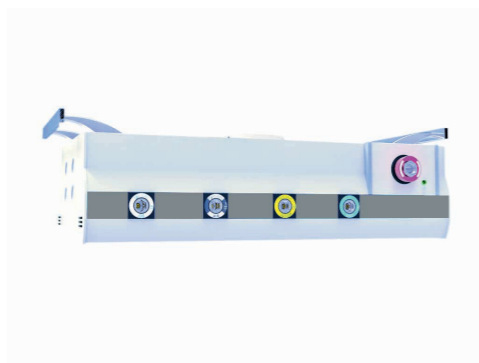

Vertical supply console „L“

- Vertical supply console for mounting installation components and trays
- With integrated vertical multi-function rack in various lengths
- Supply console available in lengths of 600, 1,000, 1,200 and 1,500 mm
- Enables space-saving positioning of e.g. 15 gas outlets, 30 electrical and data outlets, trays, drawers and much more
- Optimized cable management for operating room and intensive care unit
- Adaptable to all available Sim.CARRY suspension arm systems
- Allows individual placement of all installation components and trays and accessories
- Tool-free exchange and expansion of installation components in the console
- Wide variety of accessories available for supply consoles, such as the Sim.LED 250 examination light for fastening to standard rails



Supply console

600 mm

Equipment example

1x AGSS, 1x 7 bar compressed air / surgical air (air motor), 5x gas outlets, 5x pressure gauges, 12x 230V electrical and data outlets, 12x grounding bolts, 2x standard rails, trays, 2x multi-function rack length 600 mm

1,000 mm

1x AGSS, 1x 7 bar compressed air / surgical air (air motor), 8x gas outlets, 6x pressure gauges, 20x 230V electrical and data outlets, 20x grounding bolts, 2x standard rails, trays, 2x multi-function rack length 1,000 mm

1,200 mm

1x AGSS, 1x 7 bar compressed air / surgical air (air motor), 10x gas outlets, 6x pressure gauges, 24x 230V electrical and data outlets, 24x grounding bolts, 2x standard rails, trays, 2x multi-function rack length 1,200 mm

1,500 mm

1x AGSS, 1x 7 bar compressed air / surgical air (air motor), 12x gas outlets, 6x pressure gauges, 30x 230V electrical and data outlets, 30x grounding bolts, 2x standard rails, trays, 2x multi-function rack length 1,500 mm

Vertical supply console „Z“

- Vertical supply console with 400 mm lift for anesthesia machines
- Adapters available for all common anesthesia machines, guaranteeing maximum flexibility
- Enables space-saving placement of e.g. 10 gas outlets, 25 electrical and data outlets, trays and much more
- Wide variety of accessories available for supply consoles, such as the Sim.LED 250 examination light for fastening to standard rails

Equipment example

1x AGSS
1x 7 bar compressed air / surgical air (air motor)
10x gas outlets
6x pressure gauges
25x 230V electrical and data outlets
20x grounding bolts
4x standard rails



Sim.CARRY – THE ALL-ROUND TALENT

The Sim.CARRY ceiling supply unit boasts impressive versatility thanks to different suspension arm system variants as well as supply consoles which can be individually adapted to meet the customer's needs. This way, Sim.CARRY meets the demanding requirements of the conventional specialty disciplines in the operating room and intensive care unit.



An overview of the available suspension arm systems

Sim.CARRY 50

- Fixed column without extension arms
- Ideally suited for horizontal supply consoles



Sim.CARRY 50

Sim.CARRY 100 & 150

- One extension arm
- Available in lengths of 450, 600, 800 and 1,000 mm
- Optionally available with motor arm (800 mm)
- Suitable for vertical and horizontal supply consoles as well as supply consoles with lift for anesthesia machines (Sim.CARRY 100)

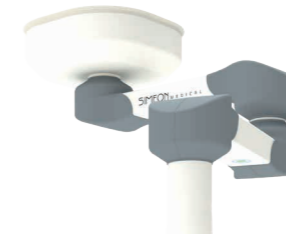

Sim.CARRY 100 with one extension arm



Sim.CARRY 150 with one motor arm

Sim.CARRY 200 & 250

- Extension arm as double combination
- Available in lengths of 450, 600, 800 and 1,000 mm (for extension arm 1 & 2)
- Maximum action radius of 2,000 mm
- Optionally available with motor arm (800 mm)
- Suitable for vertical and horizontal supply consoles as well as supply consoles with lift for anesthesia machines (Sim.CARRY 200)



Sim.CARRY 200 with two extension arms



Sim.CARRY 250 with extension and motor arm

Sim.CARRY - IDEAL FOR THE OPERATING ROOM AND IN INTENSIVE CARE

Thanks to the wide range of available suspension arm systems and modular supply consoles adaptable to the customer's needs, the Sim.CARRY ceiling supply unit guarantees ideal flexibility for the operating room and in intensive care. Furthermore, the supply consoles can be supplemented with a wide array of accessories to ideally adapt the Sim.CARRY to the requirements on site.

Accessories for Sim.CARRY ceiling supply units

SIMEON offers a wide range of suitable accessories to fit all available supply consoles.



Trays in various sizes and designs, optionally available with drawers as well



Baskets in various sizes



Brackets for various materials



Sim.LED 250 examination light for fastening to the Sim.CARRY ceiling supply unit



Monitor holders



Infusion module

Sample configuration for operating room and intensive care

General operating room

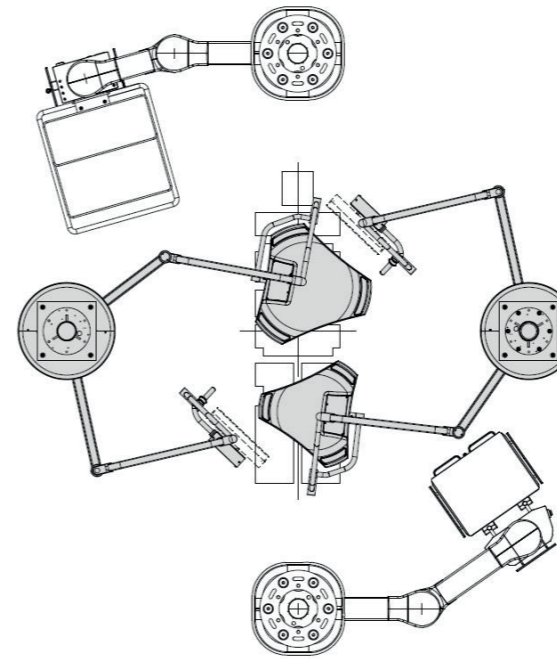

A particularly well-suited arrangement for this is a decentralized installation of two two-armed ceiling supply units (Sim.CARRY 200 or Sim.CARRY 250) with a vertical supply console. Thanks to the modular construction and availability of versatile suspension arm systems, the Sim.CARRY ceiling supply unit is perfect for equipping the operating rooms of all conventional specialized disciplines. The operating room equipment is complemented by the SIMEON operating lights available.

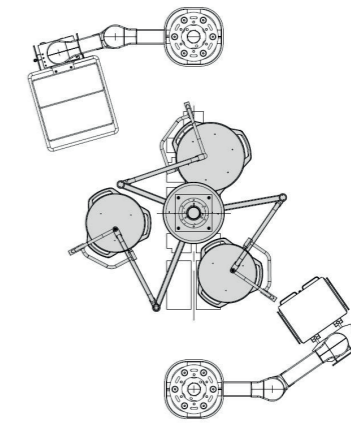

Intensive care

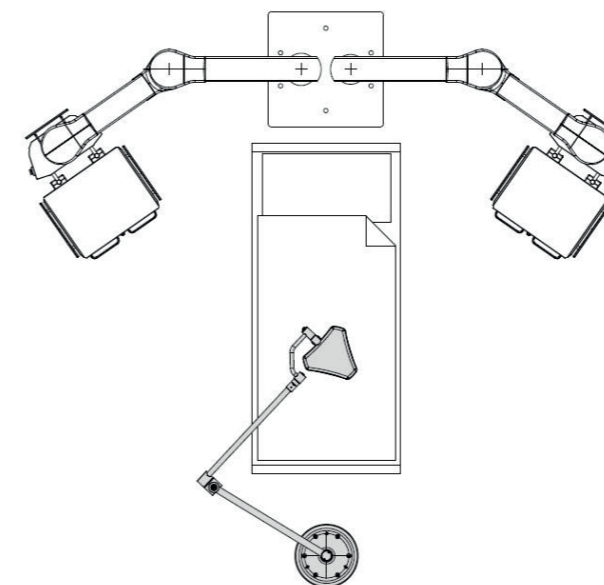

A tandem installation with a two-armed ceiling supply unit (Sim.CARRY 200 or Sim.CARRY 250) and a vertical supply console is especially well suited for intensive care. SIMEON offers a wide selection of examination lights or small operating lights for this purpose.

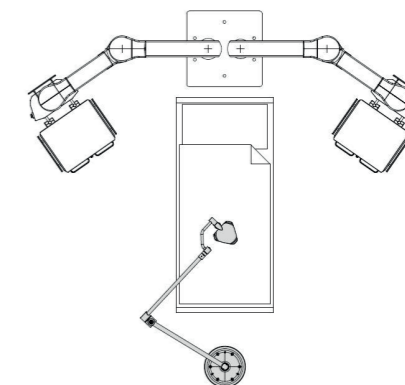

SIMEON MEDICAL YOUR HOSPITAL SOLUTION PROVIDER

SIMEON Medical, the hospital solution provider offers a wide product portfolio for the operating room as well as for other major areas of the hospital. From surgical lights and examination lights to camera- and videosystems, to the operating table and all the way to ceiling supply units – everything from a single provider and always focusing on user-friendly application on site.



Anti.BAC®

OR Lights – SIMEON HighLine
Excellent light performance.



Anti.BAC®

OR Lights – SIMEON BusinessLine
Great Light. Great Value.



Ceiling Pendants – Sim.CARRY
The all-rounder of ceiling supply units.



Camera- & Videosystems
Sim.CAM 4K Wireless
 More Details. Better Visualization.
Sim.CAM HD and HD Wireless
 More Details. Great Flexibility.
Sim.SCREEN **Anti.BAC®**
 Monitor holder for smooth and easy use.
Streaming and Recording devices
 Top quality telemedicine.
Sim.VID
 Mobile visualization of medical images

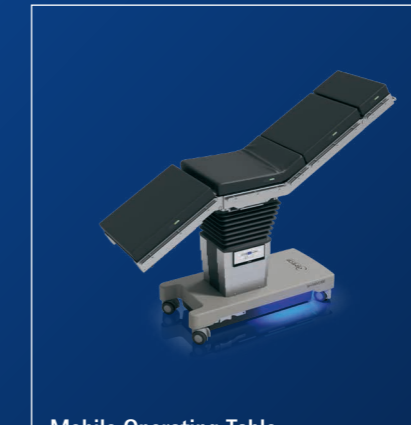

Mobile Operating Table –
Sim.MOVE 800
 Business-Class with high-end characteristics.



Anti.BAC®

Minor Surgical Light –
Sim.LED 4500
 Small operating theatre light – wide field of view.



Anti.BAC®

SIMEON Mobile lights, optionally with battery back-up
 The mobile lights are available with unique battery back-up and without battery.



Anti.BAC®

Examination Lights –
 Another dimension of light
Sim.LED 3500+
 The modern examination light.
Sim.LED 350
 Efficient and flexible in practice.
Sim.LED 250*
 Reduced to the optimum.

*Anti.BAC not applicable for Sim.LED 250

WE OFFER EXCELLENCE FOR YOUR HOSPITAL

As a hospital solution provider, SIMEON Medical has more than 20 years of experience, 100 employees at 6 sites worldwide, great innovative capacity and invaluable know-how for medical technology solutions. Thank to our proximity to our customers and understanding of their needs, we guarantee you excellent products – made in Germany*.



Innovative solutions

For SIMEON, innovation means adding value to the customer. SIMEON's products provide a great deal of flexibility, and our numerous patents are testament to their exceptional level of technical innovation; these qualities have helped SIMEON become a key company in medical technology.



Diversification

SIMEON has continuously been developing new and innovative products since its foundation, always in line with SIMEON's philosophy as a solution provider for the hospital with focus on the OR.



Global

As an internationally operating company, we sell in more than 90 countries worldwide, supported by our 6 regional sales offices.



Made in Germany

We operate on a global level – without forgetting our roots*.

*Sim.CARRY made in Czech Republic

PUSHING TECHNOLOGY TO EXCELLENCE

In recent years, we have developed to become one of the world's leading producers of hospital solutions. We operate and produce according to our philosophy "Pushing Technology to Excellence" at all times. Our work is based on three pillars: innovation, global footprint and German-made quality*.

What "Pushing Technology to Excellence" means to us:



01

Doing things right the first time



02

Providing solutions which offer significant customer benefits



03

Being a reliable business partner



04

Using resources sustainably

CONSISTENTLY TOP-NOTCH PRODUCT QUALITY

We make no compromise in the quality of our products. We produce with cutting-edge manufacturing technologies, primarily work with local and certified suppliers and exclusively use high-grade materials. We achieve and maintain our high quality standards through continuous process monitoring and improvement as well as our seamless quality management.

AN OVERVIEW OF OUR SERVICES:

01

ISO 13485:2016:
Current certification of our Quality Management System for medical device manufacturers

02

MDSAP:
Current certification of our Quality Management System in accordance with the requirements of the EU, USA, Japan, Brazil and Canada

03

ISO 14001:
Current certification of our Environmental Management System

04

UL audited: Quarterly verification of our products by UL

05

FDA: Registration at the Food and Drug Administration (FDA)

06

Known consignor:
Entitlement to secure airfreight

THE FUTURE OF OUR ENVIRONMENT AT A GLANCE

Our environment is near and dear to our hearts! So we do everything we can to secure its future. Environmental protection is one of our primary company goals. We focus on sustainable growth and a resource-conserving company policy. That way, we contribute to a healthy future worth living in.

Environmental protection at SIMEON Medical – an overview:

We save energy through the use of photovoltaic systems.

We heat and cool using geothermal boreholes and use the heat from our compressors for heat recovery.

We make our products out of high grade recyclable materials such as glass and aluminum instead of plastic. This makes our products exceptionally durable as a result.

We recycle the shavings which accumulate in production and package our products with recyclable materials whenever possible.

We are certified according to ISO 14001 for our Environmental Management System.



SIMEON MEDICAL YOUR SOLUTION PROVIDER FOR THE HOSPITAL



PUSHING TECHNOLOGY TO EXCELLENCE

S.I.M.E.O.N. Medical GmbH & Co. KG

In Grubenäcker 18

78532 Tuttlingen

Phone: +49 (0) 74 61 / 900 68 - 0

Fax: +49 (0) 74 61 / 900 68 - 900

www.simeonmedical.com

info@simeonmedical.com

As a hospital solution provider, SIMEON Medical has more than 20 years of experience, 100 employees at 6 sites worldwide, great innovative capacity and invaluable know-how for medical technology solutions. Thank to our proximity to our customers and understanding of their needs, we guarantee you excellent products – made in Germany*.

Products are only available in registered countries.

*Sim.CARRY made in Czech Republic